

Design and Optimization of Metal Matrix Composite (MMC'S) Spur Gear

J. Purushottam Karthik*

Department of mechanical engineering, R.V.R & J.C College of Engineering,
Chowdavaram, Guntur-522019, INDIA
Email : chandrakalachari@gmail.com
Corresponding author*

T. Rohith Sai

Department of Mechanical Engineering, R.V.R. & J.C College of Engineering,
Chowdavaram, Guntur, India

S. Sai Praneeth

Department of Mechanical Engineering, R.V.R. & J.C College of Engineering,
Chowdavaram, Guntur, India

Received: 26 March 2016, Revised: 12 May 2016, Accepted: 19 June 2016

Abstract: Gears are one of the most critical components in power transmission system of an automobile and also many rotating machinery. Many studies have been conducted on optimum gear design. The main objective is to design different aluminium metal matrix composite spur gears before and after optimization. Aluminium metal matrix material composites are preferred mostly due to their low density. Also the high specific mechanical properties make these alloys one of the most interesting material alternatives for the manufacture of lightweight parts for many types of vehicles. With wear resistance and strength equal to cast iron, 67% lower density and three times thermal conductivity, aluminium MMC alloys are ideal materials for the manufacture of lightweight automotive and other commercial parts. In the present work materials considered are Al 6061-T6, Al 6106-T6, Al 7075-T651, and Al 7050-T7451. Finite Element Analysis is performed on different spur gears using above materials and the results will be compared.

Keywords: Aluminum, Metal matrix composite, Optimization, Spur gear

Reference: Purushottam Karthik, J., Rohith Sai, T., Sai Praneeth., S., "Design and optimization of metal matrix composite spur gear", Int J of Advanced Design and manufacturing technology, Vol 9/No.1, 2016, pp. 49-56.

Biographical Notes: **J Purushottam Karthik** received his MSc in Mechanical Engineering from Acharya Nagarjuna University, Guntur, India in 2012. He is currently Assistant Professor in R.V.R & J.C College of Engineering, Guntur, India. His research interests are hybrid composites. **T. Rohith Sai** is currently final year student of BSc in Mechanical Engineering from R.V.R & J.C College of Engineering, Guntur, India. **S. Sai Praneeth** is currently final year student of BSc in Mechanical Engineering from R.V.R & J.C College of Engineering, Guntur, India.

1 INTRODUCTION

Gear is a rotating cylindrical wheel having teeth cut on it which transmits power/motion between two shafts by meshing with another gear without any slip. Spur gears are the simplest and most common type of gears. Spur gears have their teeth cut parallel to the axis and are used to transmit power between two parallel shafts. They have a high operating efficiency of 98-99% and are usually employed to achieve constant drive ratio.

The gear materials used for manufacture of gears depend upon the strength and the service conditions. Cast iron is widely used for the manufacture of gears due to its good wearing properties, excellent machinability and durability. Alternate materials like Aluminum are also used for the reduction of weight and noise. However, it has lower stiffness and poor damping characteristics. Also composite gears are preferred nowadays to achieve noiseless running, light weight, resistance to corrosion, lower coefficients of friction and ease of mass production. In order to compensate the above mentioned factors, Aluminum alloys are reinforced with hard ceramic particles forming Aluminum Metal Matrix Composites which have more balanced mechanical, physical and tribological characteristics. They have numerous applications in automotive industry as Brake rotors, pistons, connecting rods and integrally cast MMC engine blocks.

Optimization is the act of obtaining best result under the given circumstances. Design optimization of spur gear sets reduces the size, weight, tooth deflection and increases the life span of the gear. The optimization methodology adopted in this work is a probabilistic technique called the Ant Colony Optimization algorithm which generates the global best solution.

2 LITERATURE SURVEY

Load carrying capacity and occurring damages of gears which are made of PC/ABS blends were investigated. PC is a hard material while ABS is a soft material. The usage of materials limits these drawbacks. However, PC and ABS polymers combine each other; the PC/ABS blends have suitable mechanical properties for gear applications in the industrial areas. In this study, the usability of PC/ABS composite plastic materials as the spur gear was investigated. PC/ABS gears were tested by applying three different numbers of revolutions on the FZG experiment set. R, Yakut [1] 2009 and K. Mao [2] (2007) proposed a new design method for polymer composite gear based on the correlation between polymer gear rate and its surface temperature. M. Brahma Kumar [3] 2005 proposed that Natural Fibers are replacing synthetic fibers as reinforcement in various matrices. Incorporation of sisal-jute fiber with GFRP can

improve the properties and be used as an alternate material for glass fiber reinforced polymer composites.

S.V Prasad et al [4] 2003 contributed to the study of Aluminum Metal Matrix composites for their tribological behavior in automotive applications. Blaza Stojanovic et al., 2013 [5] studied the application of aluminum hybrid composites in Automotive Industry. Varuzan Kevorkijan et al. [6] 2002 studied the development of Aluminum metal matrix composites for automotive industry.

Huang et al [7] 2005 formulated an interactive physical programming and thereby optimized the three stage spur gear unit used for speed reduction. Vijayakumar K. et al. [8] 2003 modified the traditional ant colony algorithm by introducing a bi-level search procedure, for optimizing multi-pass turning operations. Wang et al. [9] 2004 introduced an improved heuristic algorithm named bi-directional convergence ant colony optimization for job-shop problem and proved that the ACO can solve the multi-constrained problem in less computational time. Savsani et al., [10] 2010 attempted to reduce the weight of the spur gear unit using particle swarm optimization.

Table 1. The dimensions of Spur gear

S.No	Description	Symbol	Value
1	Number of teeth	N	25
2	Module	m	3.5mm
3	Pressure Angle	α	20deg
4	Pitch circle diameter	D_p	87.5mm
5	Base circle diameter	D_b	82.23mm
6	addendum	a	3.5mm
7	Dedendum	b	4.375mm

3 MODELLING

The spur gears are designed using the solid works software. The dimensions of the spur gear taken are shown in the following table 1.

4 FINITE ELEMENT ANALYSIS

Finite Element modelling is described as the representation of the geometric model in terms of finite number of elements and nodes, which are the building blocks of the numerical

representation of the model. It is actually a numerical method employed for the solution of structures or a complex region defining a continuum. Approximate solutions are only obtained by this method. The SOLIDWORKS model is imported into the ANSYS workbench through IGES format. Meshing is done and Static Structural analysis is performed on the model. The materials considered for the analysis are the Aluminum Metal Matrix composites whose properties are listed in the table below.

Table 2. The properties of materials taken

Mechanical Properties	Al 6061-T6	Al 6106-T6	Al 7075-T651	Al 7050-T7451
Elastic Modulus (GPa)	68.9	70	71.7	71.7
Poisson's Ratio (ν)	0.33	0.33	0.33	0.33
Density (g/cc)	2.7	2.7	2.81	2.83
Ultimate Tensile Strength (MPa)	310	250	572	524
Yield Strength (MPa)	270	220	503	469

Fine tetrahedral meshing is given to the gear as it is shown in Fig. 1.

4.1 BOUNDARY CONDITIONS

The contact type chosen between the two gears was not separated. Frictionless supports were imposed to both the gear shafts which allows rotation in the Z-direction. The Moment applied was 1694.7725N-m. [11] The stress and deformation values when applied to 4 materials which were taken above are as follows.

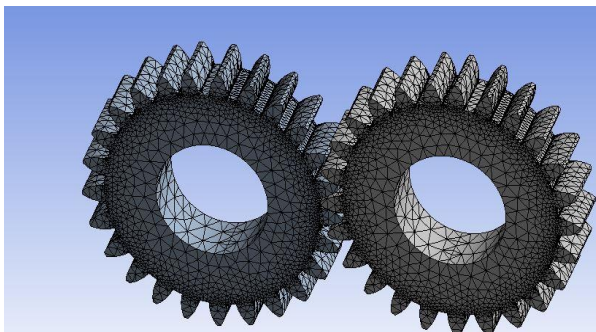

Fig. 1 The meshed model of Spur gear

4.2 ANALYSIS RESULTS

The points of maximum and minimum equivalent stresses are shown in Figs. (1 and 2), where the maximum stress obtained is 158.38MPa.

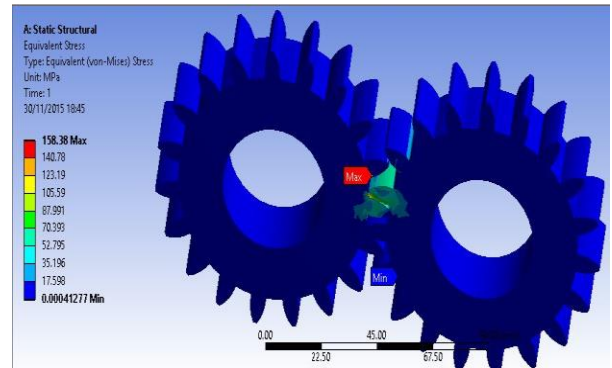

Fig. 2 The equivalent Stress on Al 7050-T7451

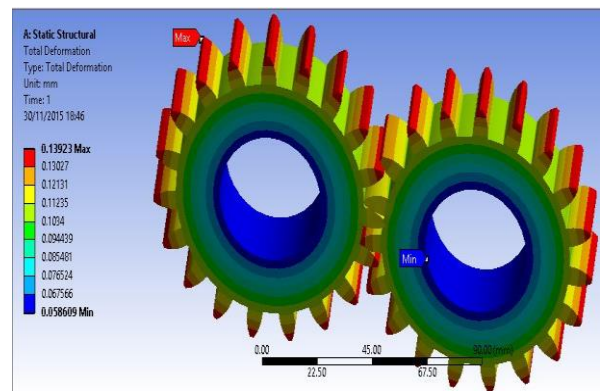

Fig. 3 Total deformation on Al 7050-T7451

The points of maximum and minimum deformations are shown and the maximum deformation obtained is 0.139mm.

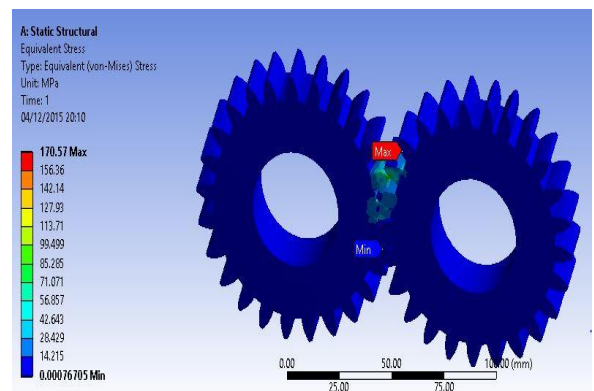

Fig. 4 Equivalent Stress on Al 7075-T651

The points of maximum and minimum equivalent stresses are shown and the maximum stress obtained is 170.57 MPa.

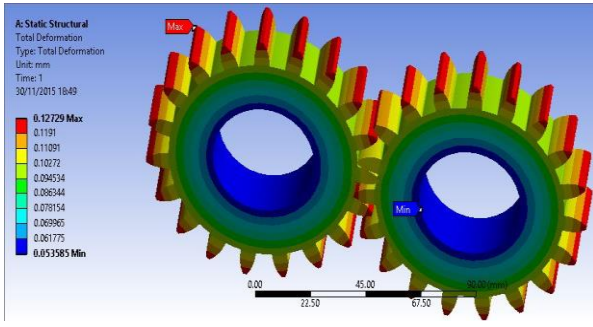

Fig. 5 Total deformation on Al 7075-T651

The points of maximum and minimum deformations are shown and the maximum deformation obtained is 0.1279mm.

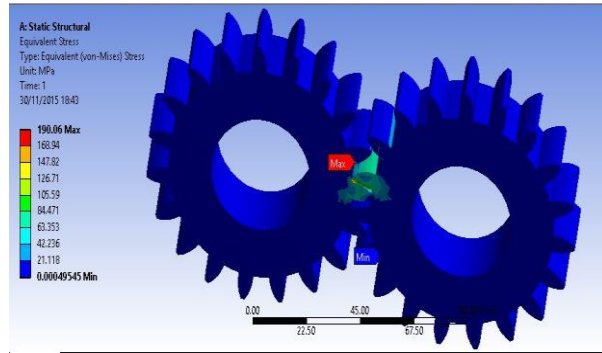

Fig. 8 The equivalent stress on Al 6061-T6

The points of maximum and minimum equivalent stresses are shown and the maximum stress obtained is 190.06MPa.

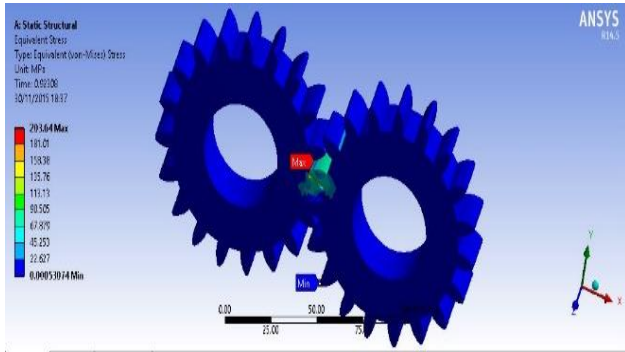

Fig. 6 The equivalent Stress on Al 6106-T6

The points of maximum and minimum equivalent stresses are shown and the maximum stress obtained is 203.64MPa.

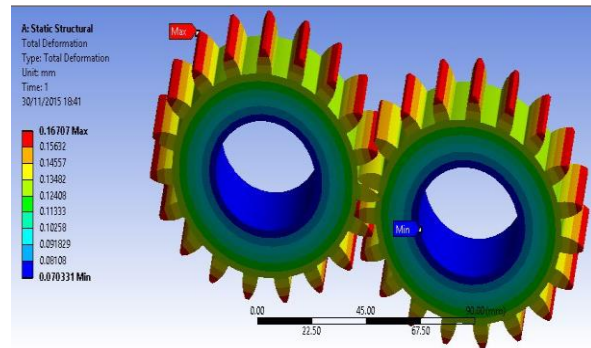

Fig. 9 Total deformation on Al 6061-T6

The points of maximum and minimum deformations are shown and the maximum deformation obtained is 0.167mm.

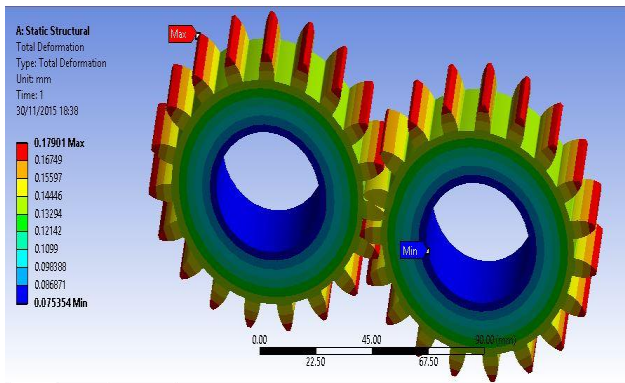

Fig. 7 Total deformation on Al 6106-T6

The points of maximum and minimum deformations are shown and the maximum deformation obtained is 0.179mm.

Table 3. The analysis Results of 4 materials

Results	Al 6061-T6	Al 6106-T6	Al 7075-T651	Al 7050-T7451
Maximum Equivalent Stress(MPa)	190.06	203.64	170.97	158.38
Maximum Deformation(mm)	0.167	0.179	0.127	0.139

From the above table of analysis results, the maximum stress for Al 7050-T7451 is 158.38Mpa which is the lowest among the 4 materials. Hence, Al 7050-T7451 and Al 7075-T651 are the best suited materials. Now, we shall consider the optimization of our gear using Ant Colony optimization.

5 ANT COLONY OPTIMIZATION (ACO)

ACO is an optimization technique inspired from ant’s natural behavior i.e. ants can identify the shortest path from its nest to food source using pheromone i.e. without visual cue. Pheromone is a chemical substance generated from the ants and that pheromone is deposited by the ants to trace the path while walking. The successive ants will more likely follow the pheromone rich path. As more ants choose a certain path, the concentration of the pheromone increases, and other ants will choose that path as the shortest path. In the optimization model, the variables to be optimized have to be divided into many intervals based on the priority. Each variable will form a column with intervals/decision variables as rows.

Thus a network has been formed which represents the solution space. Artificial ants should be allowed to pass through one node for every column/variable. After each ant reaches its final designation, the value of the fitness function has been determined based on the variable values in the nodes that were selected by an ant. This fitness function value has been normalized and then be used to determine the amount of artificial pheromone that is to be deposited on the path. The higher fitness function value results in increased pheromone and the path with higher pheromone concentrations will attract more ants to that path or the set of variables. In this manner, a set of variables/nodes forming short paths are reinforced as part of highly optimized solution. [12]

5.1 FORMULATION

ACO algorithm is used to solve the spur gear optimization problem. The formulas, equations and the data used for the design of spur gear are taken from the PSG design data book [13]. The model has been formulated as a constrained multi objective optimization problem. The spur gear is optimized by increasing the efficiency of the transmission system and reducing the size and weight of the gear. The multi objective function is denoted by equation (1).

$$f(x) = \text{avg} \left\{ \frac{f_1}{\max.f_1} + \frac{f_2}{\min.f_2} + \frac{f_3}{\min.f_3} \right\} \quad (1)$$

Where, f_1 is the maximization function for efficiency of the transmission system, and is denoted by equation 2.

$$f_1 = 100 - P_L \quad (2)$$

Where, ‘ P_L ’ is the power loss function and is calculated by equation 3.

$$P_L = \frac{50f}{\cos\phi} \times \frac{(H_s^2 + H_t^2)}{(H_s + H_t)} \quad (3)$$

‘ H_s ’ = Specific sliding velocity at the start of approach action

‘ H_t ’ = Specific sliding velocity at the end of recess action

‘ f ’ = coefficient of the friction

α = Pressure angle in degrees.

‘ H_s ’ and ‘ H_t ’ are calculated through equations 4 & 5 respectively.

$$H_t = \frac{(i+1)}{i} \times \sqrt{\frac{(r_o^2)}{(r^2)} - \cos^2\phi} \quad (4)$$

$$H_s = (i + 1) \times \sqrt{\frac{(R_o^2)}{(R^2)} - \cos^2\phi} \quad (5)$$

Where, ‘ R ’ & ‘ R_o ’ are pitch and outside circle radius of gear in mm.

‘ r ’ & ‘ r_o ’ are pitch and outside circle radius on pinion in mm.

$$r_o = r + m = (d_1/2) + m$$

$$R_o = R + m = (d_2/2) + m$$

Where, m is the module in mm, d_1 and d_2 are the pitch circle diameter of pinion and gear respectively.

f_2 is the minimization function for weight. Weight of the gear is given in equation 6.

$$f_2 = \left\{ \left[\frac{\pi}{4} \times d_1^2 \times b \times \rho \right] + \left[\frac{\pi}{4} \times d_2^2 \times b \times \rho \right] \right\} \quad (6)$$

where, ‘ d_1 ’ & ‘ d_2 ’ are the pitch circle diameter of pinion and gear wheel respectively in mm. ‘ b ’ and ‘ ρ ’ are the thickness and density of the material in kg/mm^3 respectively.

f_3 is minimization function for size, by reducing center distance between gears. Centre distance is given by equation 7.

$$f_3 = (d_1 + d_2)/2 = (m/2) * (Z_1 + Z_2) \quad (7)$$

5.2 CONSTRAINTS

The constraints considered are bending stress and crushing stress. The condition for bending stress is given in equation 8.

$$\sigma_b \leq [\sigma_b]_{\text{al}} \quad (8)$$

where ‘ $[\sigma_b]$ ’ = allowable bending stress in N/mm^2 .

‘ σ_b ’ = induced bending stress in N/mm^2 given in equation 9.

$$\sigma_b = \frac{(i+1)}{(a m b y)} \times [M_t] \quad (9)$$

Where, 'i' = gear ratio

'a' = center distance between gear and pinion.

'y' = form factor.

'[M_t]' = design twisting moment in N-mm, given in equation 10.

$$[M_t] = M_t * K * k_d \quad (10)$$

'M_t' = normal twisting moment transmitted by the pinion in N-mm.

'K' and 'k_d' are the load concentration factor and Dynamic load factor. The condition for the crushing stress is given in equation 11.

$$\sigma_c \leq [\sigma_c]_{al} \quad (11)$$

where, '[σ_c]' = allowable crushing stress in N/mm².

'σ_c' = induced crushing stress in N/mm², given in equation 12.

$$\sigma_c = 0.74 \left(\frac{i+1}{a} \right) \times \sqrt{\left[\left(\frac{i+1}{ib} \right) \times E \times [M_t] \right]} \quad (12)$$

Where, 'E' = Young's Modulus of the gear material in N/mm²

Table 4. The variables Range and Intervals

Variable	Module	Teeth
Minimum	2mm	17
Maximum	5mm	30
Interval	0.25mm	1

5.3 IMPLEMENTATION

The probability of choosing a node j by an ant from a node i using the pheromone trail τ_{ij} is given in the equation 13.

$$p_{ij}^k = \begin{cases} \frac{\tau_{ij}^\alpha}{\sum_{l \in N_i^k} \tau_{il}^\alpha}, & \text{if } j \in N_i^k \\ 0, & \text{if } j \notin N_i^k \end{cases} \quad (13)$$

Where, α is the trail parameter and N_i^k is neighborhood of ant k when is in node i. After that each ant k has moved to the next node, the evaporation of pheromones is given by equation 14.

$$\tau_{ij} \leftarrow (1 - \rho) \tau_{ij}, \forall (i, j) \in A \quad (14)$$

Where, ρ = evaporation rate.

5.4 INPUTS

The No. of ants in a trial was 25. The number of iterations was 100. α = 1 and ρ = 0.8 are taken. The MATLAB software has been used for ACO implementation. The maximization of efficiency and the minimization of size, weight were done individually, later optimal values obtained in iteration are combined through multi objective function to give a final optimal solution. [14]

5.5 OUTPUT

Module m = 4mm and Number of teeth N = 19 is obtained. With the optimized dimensions of the spur gear, the weight of gear, center distance and theoretical efficiency are calculated and compared with that of the initial gear. It is given in the table 5.

Table 5. The comparison of initial spur gear parameters with those of optimized gear

Parameters	Al 7050-T7451	Optimized Al 7050-T7451
Weight of gear (grams)	178	153
Center distance(mm)	87.5	76
Theoretical Efficiency (%)	95.19	96.96

6 ANALYSIS OF OPTIMIZED GEAR

Under the same loading conditions and constraints, Finite Element Analysis is performed on the optimized gear and the following results are obtained.

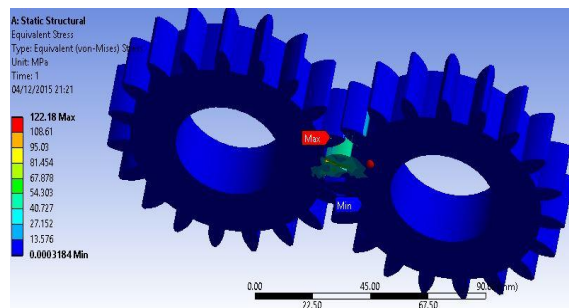

Fig. 10 The equivalent Stress on optimized gear taking Al 7050-T7451

The points of maximum and minimum equivalent stresses are shown and the maximum stress obtained is 94.99MPa.

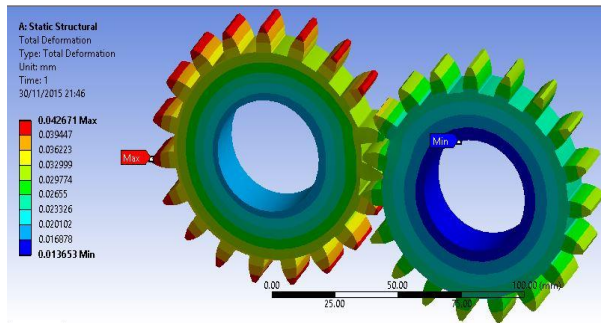

Fig. 11 Total deformation on optimized gear taking Al 7050-T6451

The points of maximum and minimum deformations are shown and the maximum deformation obtained is 0.0426mm. The maximum equivalent stress and deformation values of the optimized gear are compared with that of the initial gear.

Table 6. The analysis results comparison of optimized and initial gear

Results	Al 7050-T7451	Optimized Al 7050-T7451
Maximum Equivalent Stress(MPa)	158.38	122.18
Maximum Deformation(mm)	0.139	0.0426

7 CONCLUSION

The module of the gear taken initially was 3.5mm and the number of teeth is 24. During optimization, the module was reduced by 0.5mm, which reduced the number of teeth to 19. The gear obtained through Ant colony optimization has more efficiency, less weight and center distance. Also the maximum equivalent stresses induced in it are less than that of the initial gear. Among the 4 Aluminum materials taken, Al 7050 T7451 proved to be the better. Hence, Al 7050-T7451 is taken for the optimized gear. By the above study, it can be concluded that Aluminum metal matrix composites make lightweight gear materials suitable. Also it has been proved that Ant colony optimization can perform well by satisfying the constraints for spur gear optimization problems.

8 APPENDIX

MMC Metal Matrix composite

PC Polymer Carbonate
 FZG Folo Zone Gang
 GFRP Graphite Fiber Reinforced Plastics
 ACO Ant Colony Optimization
 IGES Initial Graphic Exchange Specification
 ABS Acrylonitrile butadiene Styrene

REFERENCES

1. R. Yakut, H. Düzcükoğlu*, M.T. Demirci Mechanical Education Department, University of Selcuk, Campus , Konya, Turkey, Received 30.09.2009; published in revised form 01.11.2009
2. K. Mao, A new approach for polyamide composite gear design, *Wear* 262 (2007) 432-441.
3. M. Brahmakumar, C. Pavithran and R.M. Pillai, Coconut fibre reinforced polyethylene composites: effect of natural waxy surface layer of the fibre on fibre/matrix interfacial bonding and strength of composites, *Composites Science and technology*, 2005.
4. S. V. Prasad, R. Asthana, “Aluminum metal matrix composites for Automotive Applications: Tribological Considerations, *Tribology Letters*, Vol. 17, No. 3, DOI: 10.1023/B.
5. Blaza Stojanovic, Lozica Ivanovic, “Application of Aluminum Hybrid Composites in Automotive Industry”, *Technical Gazette* 22, 1(2015), DOI: 10.17559
6. Varuzan kevorkijan, “Development of Aluminum MMC composites for Automotive Industry”, *Symposium: Deformation and structure of metals and alloys*, UDC:669.715/419.7:629.11=20.
7. Huang H.Z., Tian Z.G., Zuo M., Multi-Objective optimization of three stage spur gear reduction units using interactive physical programming, *Journal of Mechanical Science and technology*, 19,5,pp.1080-1086, 2005.
8. Vijayakumar K, Prabhakaran G, Asokan P, Saravanan R, “Optimization of Multi pass turning operations using ant colony system”, *International Journal of Machine tool and Manufacture*, vol.43, pp 1633-1639, 2003
9. Wang C-Q, Cao Y-F, Dai G-Z, “Bi-directional convergence ACO for job shop scheduling”, *Computer integrated manufacturing system* Vol.10 (7), pp 820-824, 2004.
10. Savsani V., R.V Rao, D.P. Vakharia, “Optimal weight design of a gear train using particle swarm optimization and stimulated annealing algorithms”, *Mechanism and Machine theory*, Vol.45, pp 531-541, 210
11. Vivek Karaveer, Ashish Mogrekar, T. Preman Reynold Joseph, “Modeling and Finite Analysis of spur gear”, *International Journal of Current Engineering and technology*, ISSN 2277-4106

12. S.K. Rajesh Khanna, A.D. Jaisree, “Ant gear optimization algorithm for helical gear designing in non-lubricated conditions”, International Journal of advances in engineering science and technology, ISSN: 2319-1120
13. PSG Design data, Faculty of Mechanical Engineering, PSG College of Technology, Design Data Book, Kalaikathir Achchangam, Coimbatore, India, 2008
14. D. Sameer Kumar, Dr. K. Ravindra, K.K.K. Sanyasi Raju, Dr. D. Nageswara Rao, “Ant colony optimization based algorithms for Engineering design published in the proceedings of CAE-07[International Conference on Computer Aided Engineering], organized by I.I.T., Madras;pp:736-743.